

Application Information Sheet

Page (s) **1** **1**

Space Heating and Domestic Hot Water Production with Fully Zoned Underfloor

Facts at a glance:

Highest possible efficiency

The heat pump uses two temperature set points (one for the underfloor and one for the DHW production) to produce the required heating at the highest efficiency as opposed to using in built direct immersion heaters.

50 degC DHW flow temperature

Domestic Hot Water flow temperatures achieved at approximately 50°C

Simple Installation

Designed to simplify installation by removing the need for complicated control logic, buffer tanks, balancing valves and hot water cylinder thermostats.

Propriety hot water tanks can be used

The Kensa DHW system can link easily to any any modern indirect DHW tank, with an indirect coil, such as the Megaflo

The larger size the coil within the tank, the better the heat transfer area and hence the better the DHW performance will be. Ideally 0.2sqm of surface area is required per kW output from the heat pump.

Principle of Operation

The Kensa compact heat pump is specifically designed to provide space heating and domestic hot water (DHW) at the highest efficiency possible with the simplest installation.

In space heating mode the system provides hot water into the underfloor heating system at generally a flow temperature of 35°C. For underfloor heating in a well insulated building this will provide adequate heating into the building at the heat pump's highest efficiency. If the insulation of the building is below current regulations then this flow temperature might need to be increased reducing the system's efficiency. Insulative floor coverings such as wood or thick carpets can also require higher flow temperatures.

If full zone control is required of all the underfloor areas then a buffer vessel is required to be fitted. The most efficient buffer vessel design for heat pumps is a two connection buffer vessel (as shown over) and fitting this will reduce short cycling while maintaining the highest efficiency of the heat pump.

The underfloor manifolds should ideally be connected using a reverse return system as this will ensure even heat flow through the underfloor zones without the use of balancing valves and the resulting increase in water pump energy.

When the DHW time clock calls for production of DHW, the three-port valve diverts the flow from the heating distribution circuit into the indirect coil within the hot water cylinder. The temperature of the water from the heat pump is raised to approximately 50°C.

When the DHW production time period ends, the three port valve switches back to the underfloor distribution and the temperature drops back to its space heating design temperature. The heat pump then reverts to space heating mode or switches off if no zones are calling for heat.

The maximum DHW temperature that the heat pump can achieve will be approximately 50-55°C. In summer, it could be higher, due to the warmer ground conditions. If 65°C is required all year round, it is recommended that an immersion heater is linked to a second channel on the DHW timeclock and this is programmed to operate for a period immediately following the DHW production. This means that the majority of the heating load for the DHW is produced using the heat pump, as opposed to using only the direct immersion heater.

If 50°C water is acceptable, then it is recommended that the immersion heater is programmed to raise the temperature to 65°C once a week using the DHW timeclock.

The larger the coil within the tank, the better the heat transfer area and hence the better the DHW performance will be. Ideally the coil should be a minimum of 0.2 sqm per kW output from the heat pump.

Continued...

Kensa Engineering Ltd

Mount Wellington, Chacewater, Truro, Cornwall, TR4 8RJ

Sales Tel: 01392 826021/2 Tech/Production/Admin 01872 862140

Fax: 01872 862440

info@kensaengineering.com

www.kensaengineering.com



Kensa Engineering Ltd—Truro, Cornwall
Company Registration Number 3739805



Application Information Sheet

Space Heating and Domestic Hot Water Production with Fully Zoned Underfloor

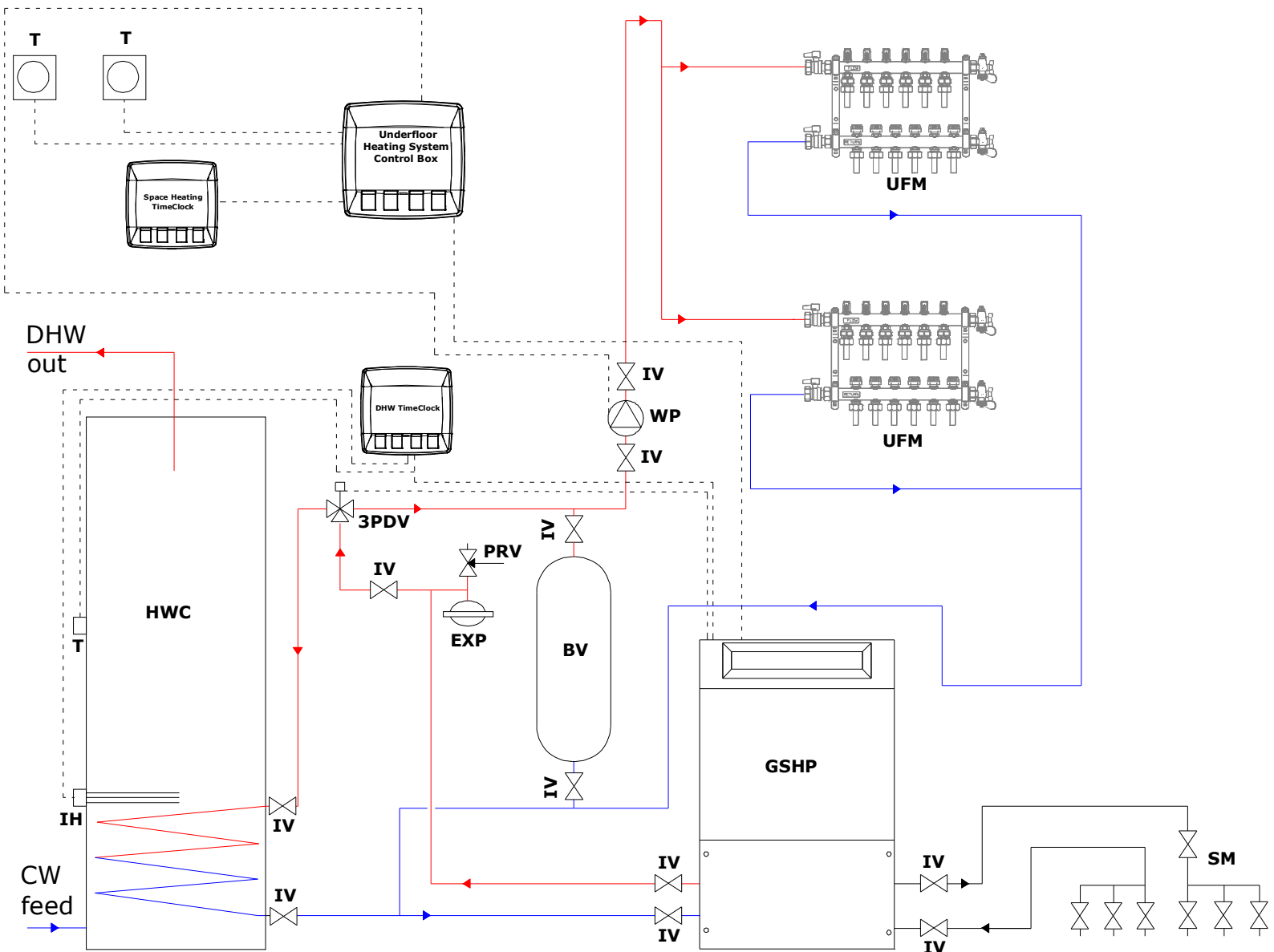

Abbreviations

- 3PDV - 3 port diverting valve
- BV - Buffer vessel
- DHW - Domestic Hot Water
- CW - Cold Water
- EXP - Expansion vessel
- GSHP - Ground source heat pump
- IH - Immersion heater
- IV - Isolation valve
- PRV - Pressure relief valve
- SM - Slinky manifold
- UFM - Underfloor manifold
- WP - Water pump

Please note:- The above drawing is a schematic only and additional valves and fittings may be required.

Please note:- Kensa supply is the ground source heat pump, slinky manifold and 3 port diverting valve. Kensa also supplies the horizontal ground arrays and antifreeze (not shown above).

The buffer vessel (BV) is fitted to reduce short cycling of the heat pump while still allowing full zone control of the underfloor.