

Application Information Sheet

Page (s) **1** **1**

Bi-Valent Space Heating with Underfloor and DHW

Facts at a glance:

Highest possible efficiency

Utilises the heat pump's high efficiency to produce the majority of space heating and uses two temperature set points (one for the underfloor and one for the DHW production) to produce the required heating at the highest efficiency as opposed to using in built direct immersion heaters.

Either or control logic

Control logic avoids the secondary boiler taking the whole heating load resulting in the heat pump never operating.

Simple Installation

Designed to simplify installation by removing the need for complicated control logic.

Easily adjustable

The point at which the secondary boiler takes over from the heat pump can easily be adjusted by use of the outside temperature sensor.

50 degC DHW flow temperature

Domestic Hot Water flow temperatures achieved at approximately 50°C using the heat pump alone.

Propriety hot water tanks can be used

The Kensa DHW system can link easily to any modern indirect DHW tank with a suitably sized in-direct coil.

Principle of Operation

Bi-valent systems utilise a secondary boiler, which is designed to provide heat into the distribution system when the heat pump isn't sized for 100% of the peak load.

They are generally found in retro-fit applications where insulation levels of the building are not sufficient and a heat pump cannot meet all off the heating load effectively.

Bi-valent systems have to be carefully designed to avoid the return temperature of the heating circuit being too high. If this return temperature is above the in-built temperature set point at which the heat pump turns off, the heat pump will never actually turn on and the whole of the load will be taken by the secondary boiler, resulting in higher than expected energy bills and carbon emissions.

The simplest and most effective way of providing the maximum efficiency of a bi-valent heating system while retaining the clients comfort is to use an either or control logic. Simply put either the heat pump or the secondary boiler is operating, but not both together.

The system operates by use of an external temperature sensor (TS). This is set at to an external temperature above which the heating load is satisfied by the heat pump alone. If the external ambient temperature drops below this set point then the heat pump is switched off and the secondary boiler switched on and supplies heat into the heating distribution system. Due to the higher output temperature of the secondary boiler it is important that the boilers flow is mixed, via a mixing valve (MV) with the return flow to lower the temperature to a suitable level for the heating distribution system.

For production of DHW, the control logic should determine which appliance is currently operating and when the DHW time clock calls, the corresponding three-port valve diverts the flow from the heating distribution circuit into the indirect coil within the hot water cylinder. If the heat pump is operating the temperature of the water from the heat pump is raised to approximately 50°C.

When the DHW production time period ends, the three port valve switches back to the underfloor distribution and for the heat pump, this reverts to space heating mode and the temperature drops back to its space heating design temperature or switches off if no zones are calling for heat.

The maximum DHW temperature that the heat pump can achieve will be approximately 50-55°C. In summer, it could be higher, due to the warmer ground conditions. If 65°C is required all year round, it is recommended that an immersion heater is linked to a second channel on the DHW timeclock and this is programmed to operate for a period immediately following the

Continued...

Kensa Engineering Ltd
Mount Wellington, Chacewater, Truro, Cornwall, TR4 8RJ
Tel: 01872 862140 Fax: 01872 862440
info@kensaengineering.com
www.kensaengineering.com

Copyright ©2009 Kensa Engineering Ltd



Kensa Engineering Ltd—Truro, Cornwall
 Company Registration Number 3739805



Application Information Sheet

Bi-Valent Space Heating with Underfloor and DHW

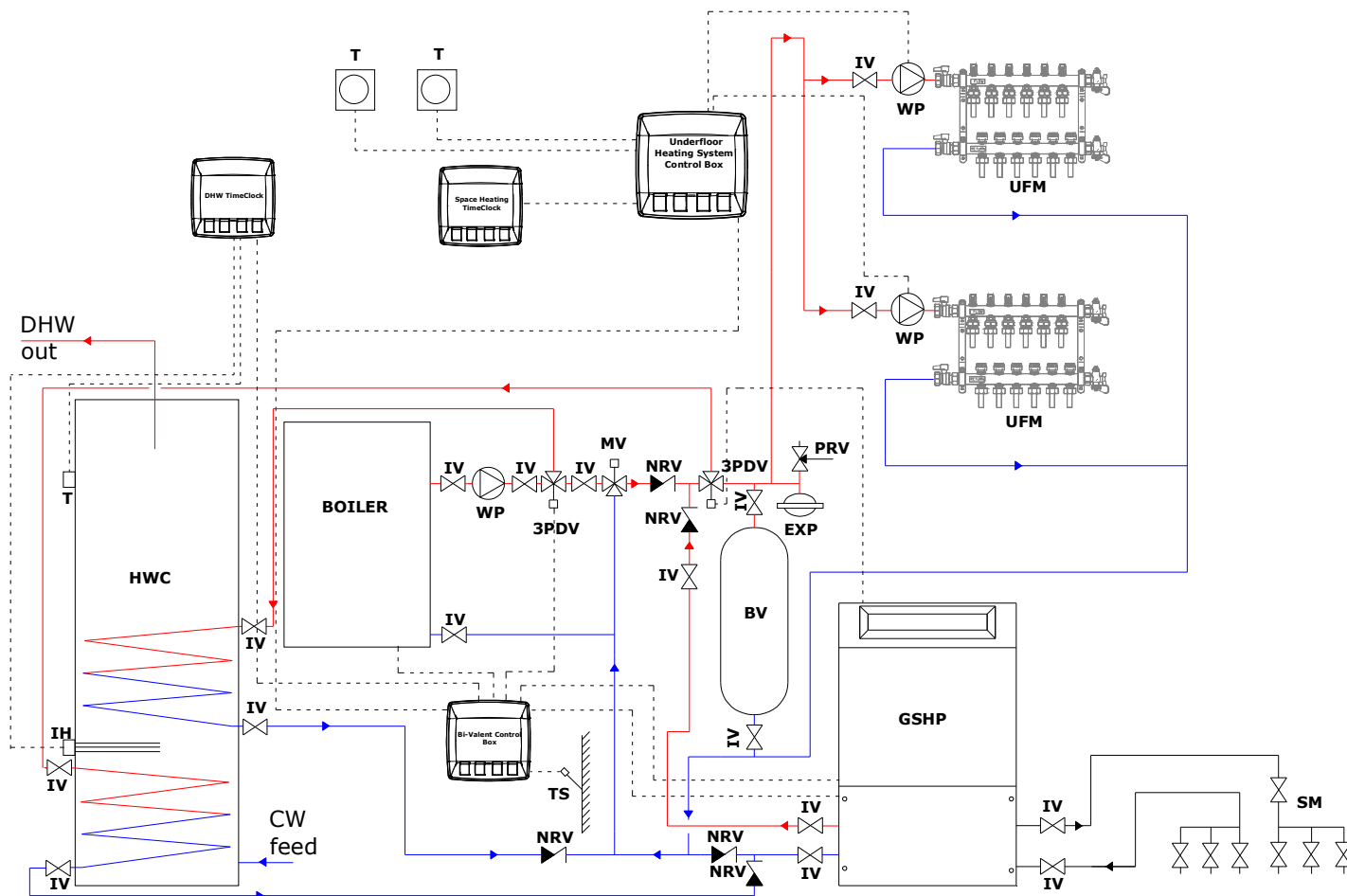

DHW production. This means that the majority of the heating load for the DHW is produced using the heat pump, as opposed to using only the direct immersion heater.

If 50°C water is acceptable, then it is recommended that the immersion heater is programmed to raise the temperature to 65°C at least once a week using the DHW timeclock.

For single coil tanks it is advised that the boiler produces all of the DHW and the heat pump is dedicated to space heating only.

Please note:- The above drawing is a schematic only and additional valves and fittings maybe required. 3 port valve orientation will depend on the manufacture of the valve.

Please note:- Kensa supply is the ground source heat pump and slinky manifold . Kensa also supplies the horizontal ground arrays and antifreeze (not shown above).

The buffer vessel (BV) is an optional item and can be fitted to reduce short cycling of the heat pump. If 25% of the underfloor zones are left open this is not required.

Abbreviations

- 3PDV - 3 Port diverting valve
- BV - Buffer vessel
- CW - Cold water
- DHW - Domestic hot water
- EXP - Expansion vessel
- GSHP - Ground source heat pump
- IH - Immersion heater
- IV - Isolation valve
- HWC - Hot water cylinder
- MV - Mixing valve
- NRV - Non return valve
- PRV - Pressure relief valve
- SM - Slinky manifold
- T - Thermostat
- TS - Temperature Sensor
- UFM - Underfloor manifold
- WP - Water pump