

Bi-Valent Space Heating with Underfloor

Facts at a glance:

Highest possible efficiency

Utilises the heat pump's high efficiency to produce the majority of space heating.

Either or control logic

Control logic avoids the secondary boiler taking the whole heating load resulting in the heat pump never operating.

Simple Installation

Designed to simplify installation by removing the need for complicated control logic.

Easily adjustable

The point at which the secondary boiler takes over from the heat pump can easily be adjusted by use of the outside temperature sensor.

Principle of Operation

Bi-valent systems utilise a secondary boiler, which is designed to provide heat into the distribution system when the heat pump isn't sized for 100% of the peak load.

They are generally found in retro-fit applications where insulation levels of the building are not sufficient and a heat pump cannot meet all off the heating load effectively.

Bi-valent systems have to be carefully designed to avoid the return temperature of the heating circuit being too high. If this return temperature is above the in-built temperature set point at which the heat pump turns off, the heat pump will never actually turn on and the whole of the load will be taken by the secondary boiler, resulting in higher than expected energy bills and carbon emissions.

The simplest and most effective way of providing the maximum efficiency of a bi-valent heating system while retaining the clients comfort is to use an either or control logic. Simply put either the heat pump or the secondary boiler is operating, but not both together.

The system operates by use of an external temperature sensor (TS). This is set at to an external temperature above which the heating load is satisfied by the heat pump alone. If the external ambient temperature drops below this set point then the heat pump is switched off and the secondary boiler switched on and supplies heat into the heating distribution system. Due to the higher output temperature of the secondary boiler it is important that the boilers flow is mixed, via a mixing valve (MV) with the return flow to lower the temperature to a suitable level for the heating distribution system.

For further information please contact Kensa Engineering Ltd on 01872 862140

Continued...

Kensa Engineering Ltd
Mount Wellington, Chacewater, Truro, Cornwall, TR4 8RJ
Tel: 01872 862140 Fax: 01872 862440
info@kensaengineering.com
www.kensaengineering.com

Copyright ©2009 Kensa Engineering Ltd



Kensa Engineering Ltd—Truro, Cornwall
Company Registration Number 3739805



Bi-Valent Space Heating with Underfloor

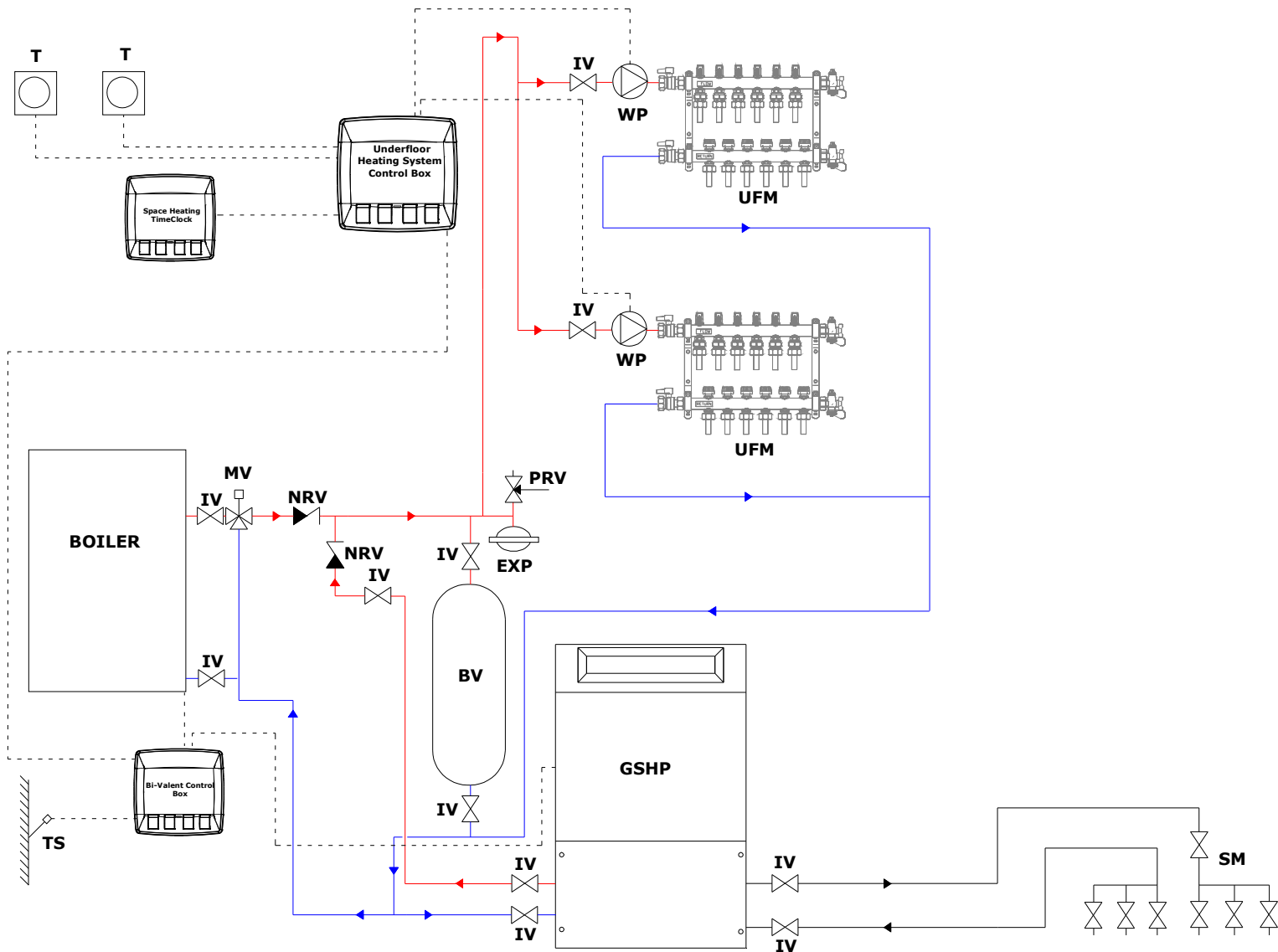

Abbreviations

- BV - Buffer vessel
- EXP - Expansion vessel
- GSHP - Ground source heat pump
- IH - Immersion heater
- IV - Isolation valve
- MV - Mixing valve
- NRV - Non return valve
- PRV - Pressure relief valve
- SM - Slinky manifold
- T - Thermostat
- TS - Temperature Sensor
- UFM - Underfloor manifold
- WP - Water pump

Please note:- The above drawing is a schematic only and additional valves and fittings may be required.

Please note:- Kensa supply is the ground source heat pump and slinky manifold . Kensa also supplies the horizontal ground arrays and anti-freeze (not shown above).

The buffer vessel (BV) is an optional item and can be fitted to reduce short cycling of the heat pump. If 25% of the underfloor zones are left open this is not required.