

Application Information Sheet

Page (s) **1** **1**

Space Heating with Underfloor and Domestic Hot Water Production via Solar and Ground Source Heat Pump. (Twin Coil)

Facts at a glance:

Highest possible efficiency

The heat pump uses two temperature set points (one for the underfloor and one for the DHW production) to produce the required heating at the highest efficiency as opposed to using in built direct immersion heaters.

Free DHW in the summer

The solar thermal will provide around 70% of the DHW requirements free.

Off-peak tariffs

Off-peak tariffs can be used to reduce the costs of running the heat pump, however it is important that the production of DHW during off-peak periods does not decrease the amount of energy going into the space heating during these periods. This might result in the space heating having to run at peak times with a higher running costs.

Ground Arrays

As there is an additional load on the ground for DHW from the heat pump the amount of ground arrays need to be increased.

Twin Coil tanks

The larger the coil within the tank connected to the heat pump, the better the DHW performance.

The Kensa compact heat pump is specifically designed to provide space heating and domestic hot water (DHW) at the highest efficiency possible with the simplest installation. It is designed to be easily integrated with a twin coil solar domestic hot water cylinder which will provide free DHW during the summer, backed up with the ground source heat pump during the winter.

In space heating mode the system provides hot water into the underfloor heating system at generally a flow temperature of 35°C. If the insulation of the building is below current regulations then this flow temperature might need to be increased reducing the system's efficiency. Insulative floor coverings such as wood or thick carpets can also require higher flow temperatures.

To avoid short cycling of the heat pump it is advised that 25% of the zones on the underfloor manifolds are left hydraulically open to provide a minimum load on the heat pump. These zones are usually the bathrooms and halls. (Alternatively a buffer vessel can be used). Any mixing valves on manifolds should also be removed to provide maximum heat into the underfloor zones.

The underfloor manifolds should ideally be connected using a reverse return system as this will ensure even heat flow through the underfloor zones without the use of balancing valves and the resulting increase in water pump energy.

During the summer all of the DHW production is provided free by the solar thermal system, however during the winter the heat pump can be used to produce DHW. When the DHW time clock calls for production of DHW, the three-port valve diverts the flow from the heating distribution circuit into the indirect coil within the hot water cylinder. The temperature of the water from the heat pump is raised to approximately 55°C.

When the DHW production time period ends, the three port valve switches back to the underfloor distribution and the temperature drops back to its space heating design temperature. The heat pump then reverts to space heating mode or switches off if no zones are calling for heat.

The maximum DHW temperature that the heat pump can achieve will be approximately 50-55°C. If 65°C is required all year round, it is recommended that an immersion heater is linked to a second channel on the DHW timeclock and this is programmed to operate for a period immediately following the DHW production. This means that the majority of the heating load for the DHW is produced using the heat pump, as opposed to using only the direct immersion heater.

If 50°C water is acceptable, then it is recommended that the immersion heater is programmed to raise the temperature to 65°C once a week using the DHW timeclock.

Kensa Engineering Ltd
 Mount Wellington, Chacewater, Truro, Cornwall, TR4 8RJ
 Tel: 01872 862140 Fax: 01872 862440
 info@kensaengineering.com
 www.kensaengineering.com

Copyright ©2009 Kensa Engineering Ltd

Certificate Number MCS1216
Heat PumpsKensa Engineering Ltd
Truro, Cornwall
Company Registration
Number 3739805

Application Information Sheet

Space Heating with Underfloor and Domestic Hot Water Production via Solar and Ground Source Heat Pump. (Twin Coil)

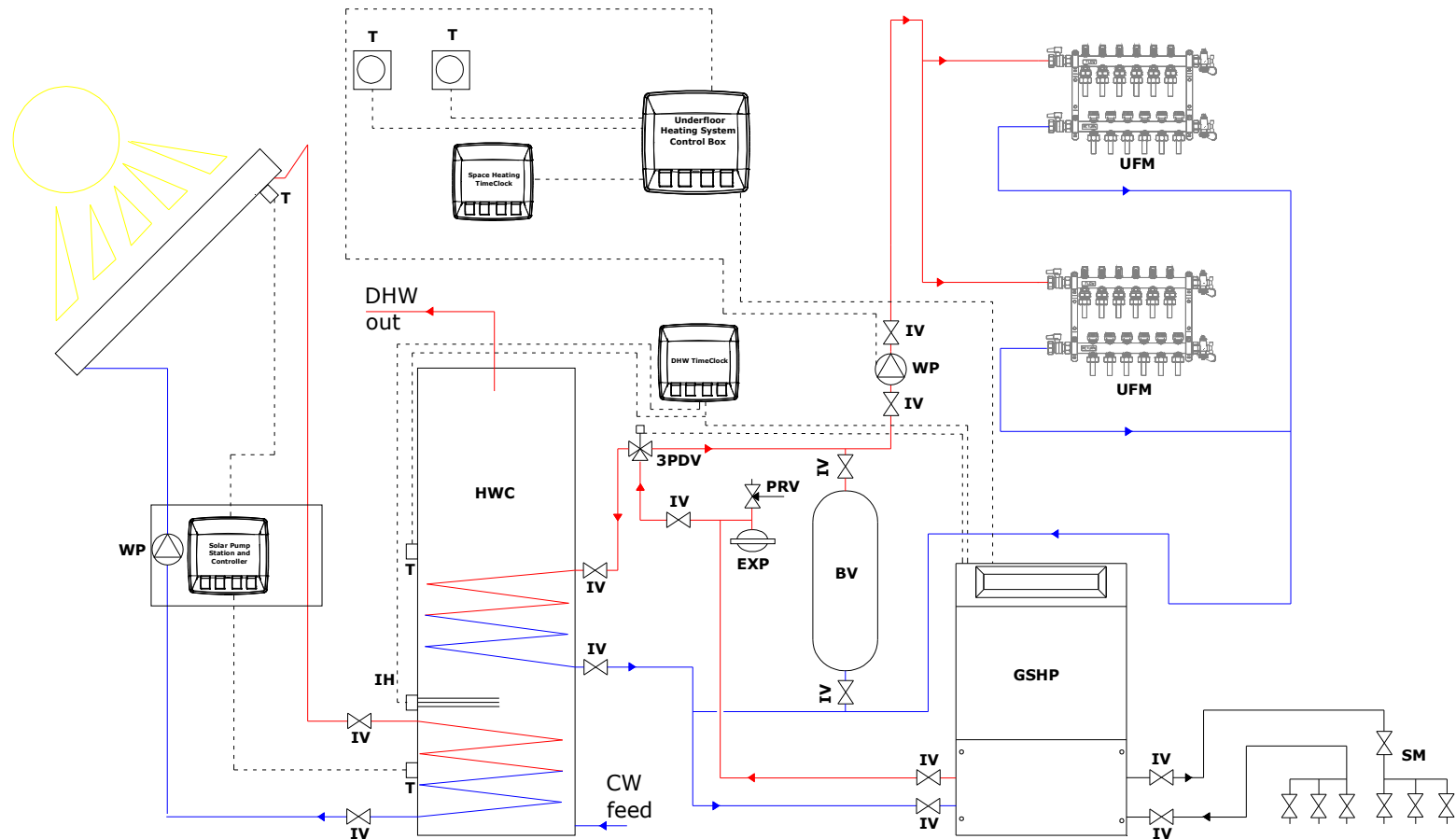

Abbreviations

- 3PDV - 3 port diverting valve
- BV - Buffer Vessel
- DHW - Domestic Hot Water
- CW - Cold Water
- EXP - Expansion vessel
- GSHP - Ground source heat pump
- IH - Immersion heater
- IV - Isolation valve
- PRV - Pressure relief valve
- SM - Slinky manifold
- T - Thermostat
- UFM - Underfloor manifold
- WP - Water pump

The Buffer Vessel (BV) is an optional item and can be fitted to reduce short cycling of the heat pump and provide close temperature control for all zones. If 25% of the underfloor zones and radiators are left open this is not required.

Please note:- The above drawing is a schematic only and additional valves and fittings maybe required.

Please note:- Running the GSHP to produce DHW with off-peak tariffs might result in the GSHP needing to operate during peak electricity periods for space heating with higher associated running costs.