

Application Information Sheet

Page (s) **1** **1**

Space Heating and Domestic Hot Water Production with Underfloor

Facts at a glance:

Highest possible efficiency

The heat pump uses two temperature set points (one for the underfloor and one for the DHW production) to produce the required heating at the highest efficiency as opposed to using in built direct immersion heaters.

50 degC DHW flow temperature

Domestic Hot Water flow temperatures achieved at approximately 50°C

Simple Installation

Designed to simplify installation by removing the need for complicated control logic, buffer tanks, balancing valves and hot water cylinder thermostats.

Oversized hot water coils are required

The larger size the coil within the tank, the better the heat transfer area and hence the better the DHW performance will be. Due to the low flow temperatures generated by the heat pump the hot water tank must have an oversized coil to provide the correct heat transfer.

Principle of Operation

The Kensa compact heat pump is specifically designed to provide space heating and domestic hot water (DHW) at the highest efficiency possible with the simplest installation.

In space heating mode the system provides hot water into the underfloor heating system at generally a flow temperature of 35°C. For underfloor heating in a well insulated building this will provide adequate heating into the building at the heat pump's highest efficiency. If the insulation of the building is below current regulations then this flow temperature might need to be increased reducing the system's efficiency. Insulative floor coverings such as wood or thick carpets can also require higher flow temperatures.

To avoid short cycling of the heat pump it is advised that 25% of the zones on the underfloor manifolds are left hydraulically open to provide a minimum load on the heat pump. These zones are usually the bathrooms and halls. Any mixing valves on manifolds should also be removed to provide maximum heat into the underfloor zones.

The underfloor manifolds should ideally be connected using a reverse return system as this will ensure even heat flow through the underfloor zones without the use of balancing valves and the resulting increase in water pump energy.

When the DHW time clock calls for production of DHW, the three-port valve diverts the flow from the heating distribution circuit into the indirect coil within the hot water cylinder. The temperature of the water from the heat pump is raised to approximately 50°C.

When the DHW production time period ends, the three port valve switches back to the underfloor distribution and the temperature drops back to its space heating design temperature. The heat pump then reverts to space heating mode or switches off if no zones are calling for heat.

The maximum DHW temperature that the heat pump can achieve will be approximately 50-55°C. If 65°C is required all year round, it is recommended that an immersion heater is linked to a second channel on the DHW timeclock and this is programmed to operate for a period immediately following the DHW production. This means that the majority of the heating load for the DHW is produced using the heat pump, as opposed to using only the direct immersion heater. If 50°C water is acceptable, then it is recommended that the immersion heater is programmed to raise the temperature to 65°C once a week using the DHW timeclock.

Continued...

Kensa Engineering Ltd
 Mount Wellington, Chacewater, Truro, Cornwall, TR4 8RJ
 Tel: 01872 862140 Fax: 01872 862440
 info@kensaengineering.com
 www.kensaengineering.com

Copyright ©2009 Kensa Engineering Ltd



Certificate Number MCS1216
Heat Pumps

Kensa Engineering Ltd
 Truro, Cornwall
 Company Registration
 Number 3739805



Application Information Sheet

Space Heating and Domestic Hot Water Production with Underfloor

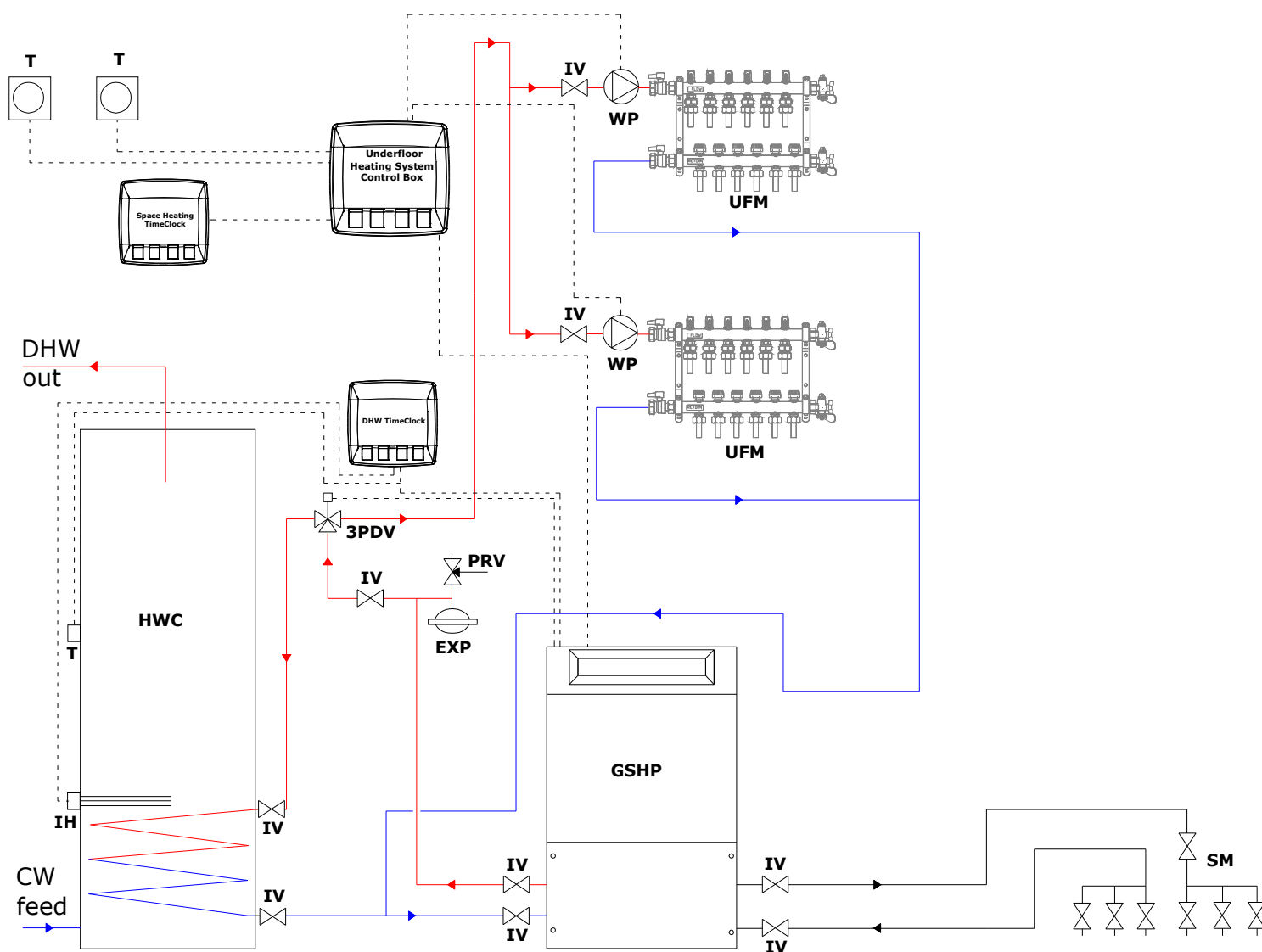

Please note:- The above drawing is a schematic only and additional valves and fittings may be required.

Please note:- Kensa supply is the ground source heat pump, DHW cylinder, slinky manifold and 3 port diverting valve. Kensa also supplies the horizontal ground arrays and antifreeze (not shown above).

The above installation schematic is based on 25% of the underfloor zones being open i.e. with no control valves fitted, hence removing the need for a buffer tank.

Please note:- Running the GSHP to produce DHW with off-peak tariffs might result in the GSHP needing to operate during peak electricity periods for space heating with higher associated running costs.

Abbreviations

3PDV	- 3 port diverting valve
DHW	- Domestic Hot Water
CW	- Cold Water
EXP	- Expansion vessel
GSHP	- Ground source heat pump
HWC	- Hot water cylinder
IH	- Immersion heater
IV	- Isolation valve
PRV	- Pressure relief valve
SM	- Slinky manifold
UFM	- Underfloor manifold
WP	- Water pump