

Application Information Sheet

Page (s) **1** **1**

Twin Domestic Hot Water (DHW) Tank Systems

Facts at a glance:

Reduced Running Costs

For large occasional DHW loads it can be more cost effective to use two hot water cylinders as opposed to a large single hot water tank where a large volume of water is kept hot all year round for little use.

Reduced Capital Costs

Two smaller hot water cylinders can cost less than one large cylinder due to material specification and manufacturing costs.

Coil Size

Each hot water cylinder should have the correct oversized coil for the heat pumps maximum output .

Piping Arrangements

The hot water cylinders need to be piped as a reverse return configuration and the cylinders should be identical to ensure equal flow to each cylinder.

In certain applications it becomes more cost effective both in capital terms and running costs to use two hot water cylinders as opposed to one large cylinder. For example if the property only requires a large hot water demand on a few occasions through out the year, such as at Christmas or two weeks through the summer when additional family members visit. It is possible to run only one cylinder for the majority of the time and run two cylinders during these high hot water demand periods. This will also provide lower running costs as a single large cylinder would mean that a large volume of water is kept hot at all times unnecessarily.

Another reason is there can also be a higher capital cost for the larger tanks due to the material specification and manufacturing processes i.e. thicker material with higher rolling costs, and using two smaller tanks to provide the same storage may well be more cost effective.

The coil within the cylinder needs to be correctly sized for the heat pump to provide effective heat transfer at the lower temperature produced by the heat pump. The correct coil size needs to be in both cylinders as there will be times when only one cylinder is required. While it is acceptable to have a larger surface area of coil than is required by the heat pump, it is not advisable to have a smaller coil than required by the heat pump as this can lead to poor DHW performance.

If two tanks are selected then the flow and return to each cylinder should be connected in a reverse return configuration and the tanks need to be identical. This ensures that the pressure drop and hence flow to each cylinder is kept equal when both tanks are operational. This does mean that the cylinders are ideally kept close to each other (to reduce piping costs and pipe run issues) and ideally they should also be close to the heat pump to reduce pipe losses.

If the space for the footprint of two cylinders is available using two cylinders is an effective solution to high occasional hot water demands.

Kensa Engineering Ltd
Mount Wellington, Chacewater, Truro, Cornwall, TR4 8RJ
Tel: 01872 862140 Fax: 01872 862440
info@kensaengineering.com
www.kensaengineering.com

Copyright ©2009 Kensa Engineering Ltd



Certificate Number MCS1216
Heat Pumps

Kensa Engineering Ltd
 Truro, Cornwall
 Company Registration
 Number 3739805



Application Information Sheet

Twin Domestic Hot Water (DHW) Tank Systems

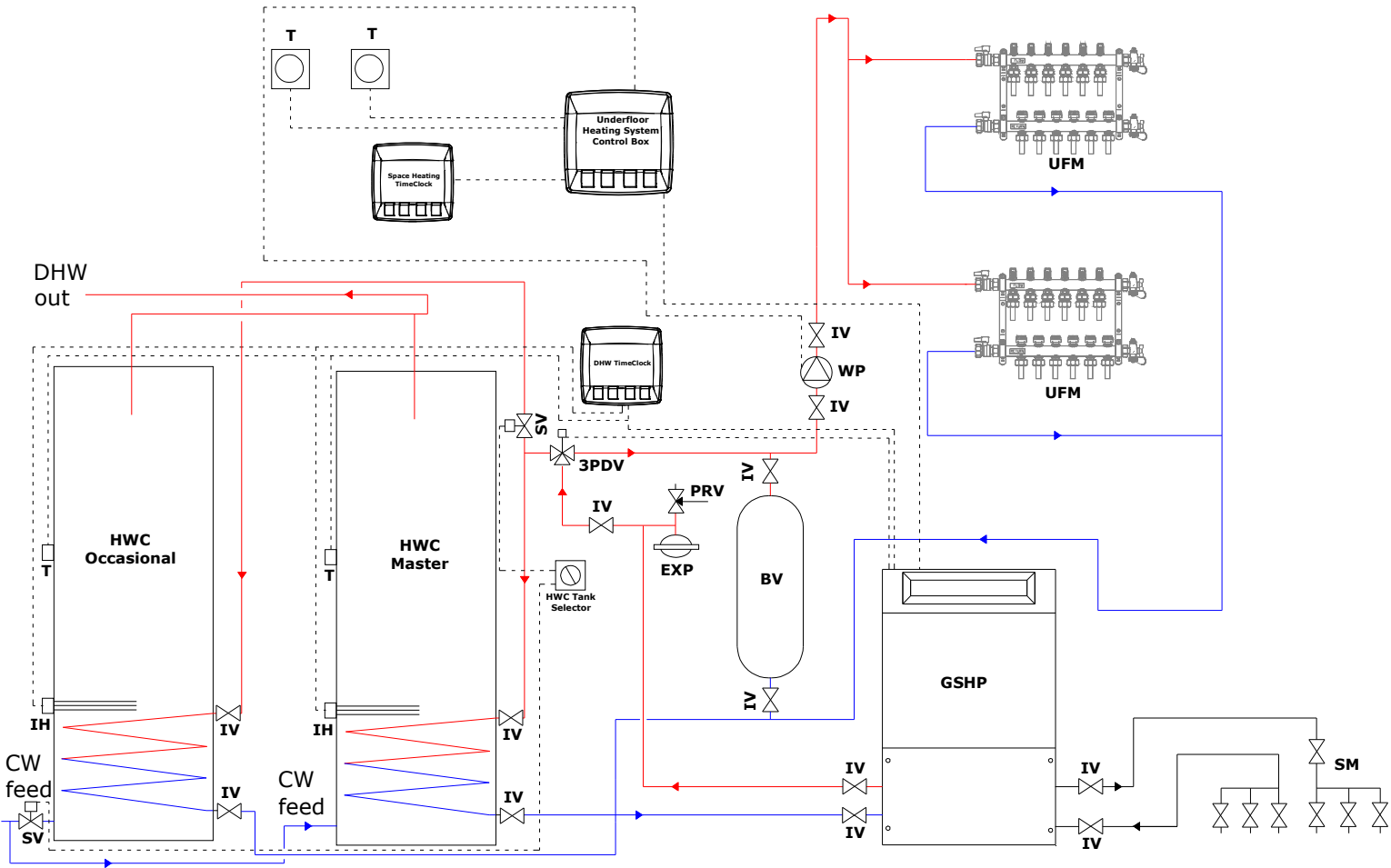

Abbreviations

- 3PDV - 3 Port Diverting Valve
- BV - Buffer Vessel
- CW - Cold Water
- DHW - Domestic Hot Water
- EXP - Expansion Vessel
- GSHP - Ground source heat pump
- IH - Immersion heater
- IV - Isolation valve
- HWC - Hot Water Cylinder
- PRV - Pressure Relief Valve
- SV - Solenoid Valves
- T - Thermostat
- WP - Water pump

Please note:- To ensure equal flow to both hot water cylinders, when in use at the same time, all pipework (flow and return) to and from the cylinders should be piped reverse return. (Not shown for clarity)

Please note:- The above drawing is a schematic only and additional valves and fittings maybe required. The actual installation will vary depending on the application.

Please note:- Kensa supply is the ground source heat pump, buffer vessels and hot water cylinders. Kensa also supplies the ground array manifolds and antifreeze (not shown above).